

Rorschach's River's Rules

General Rules

Draw a directed path through the centres of some cells which enters the grid through the arrow at the top and exits the grid through the arrow at the bottom.

The puzzle is divided into 50 subgrids. Each subgrid has a different ruleset and covers 13 or 16 rows, such that it has 10 rows to itself and two consecutive subgrids overlap by 3 rows. In these overlapping sections, apply all rules from both subgrids.

Unless specified otherwise for an individual subgrid, the path moves horizontally and vertically between adjacent cells and cannot branch or cross itself. For subgrids that allow the path to move at an angle, consider the path a sequence of cell centres and draw straight lines connecting them. Only cells in this sequence are considered *visited*, but all cells which contain a non-zero length of the path are considered *passed through*. (Note that some subgrids do allow the path to cross itself.)

Clues can generally see cells and path segments outside their own subgrid **unless specified otherwise**.

Black cells are never part of the grid and cannot be visited (but may be passed through). Some subgrids ask the solver to shade some cells. The path can never visit a shaded cell.

Some rulesets refer to *regions*

Example puzzles by Wessel Strijkstra, TheGreatEscaper and Menderbug.

#3 **Masyu** (rows 24 – 39) by Lavaloid

The path visits every circle. The path turns on black circles and travels straight through the cells on either side. The path goes straight through white circles, and turns in at least one of the cells on either side.

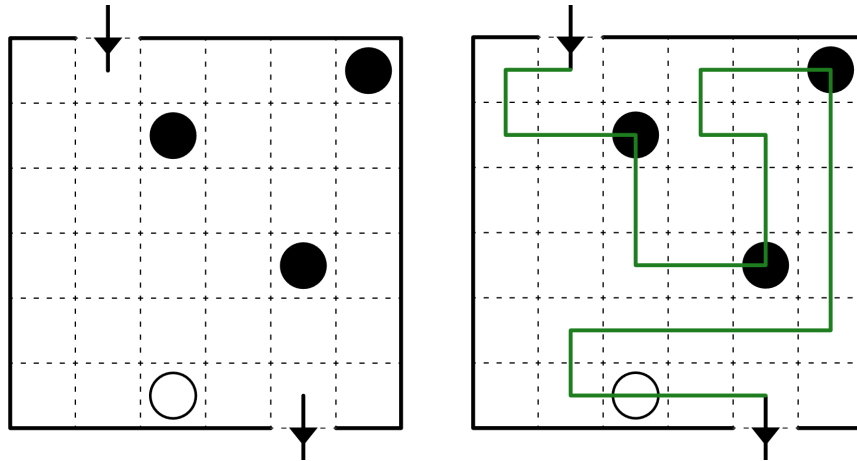

[Solve on Penpa+](#)

#4 **NIKOJI Path Data** (rows 37 – 52) by Andy Tockman (tckmn)

The path visits every letter clue. It must be possible to divide the path within this subgrid at grid edges into sections, such that: (a) each section contains exactly one clue, (b) all sections containing the same letter have the same shape **without rotation or reflection**, but with arbitrary segment lengths, with the letter appearing on the same turn or straight segment, (c) different letters do not correspond to the same shape, **not even rotated or reflected and ignoring the letter positions**. This subdivision into sections is not necessarily unique, due to the variable segment lengths.

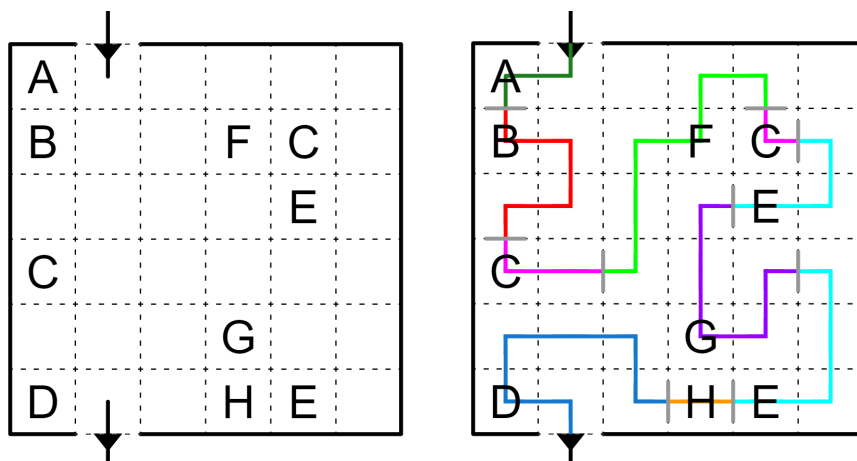

[Solve on Penpa+](#)

#5 **Tapa-Like Path** (rows 50 – 65) by Michael Tang

The path cannot visit clue cells. Clues represent the numbers of consecutive cells occupied by the path each time it enters the (up to) eight cells surrounding the clue.

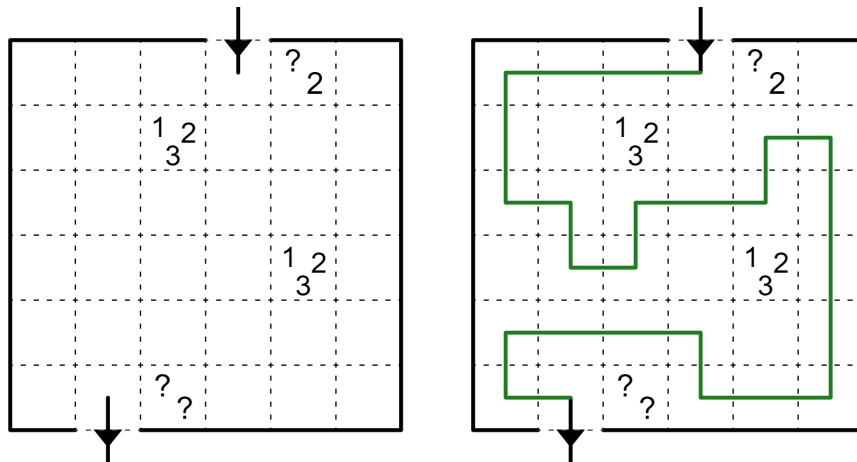

[Solve on Penpa+](#)

#6 **Poopapath** (rows 63 – 78) by Botaku

The path visits every cell. Reading along the path, the letter clues in this subgrid must repeatedly spell out POOP.

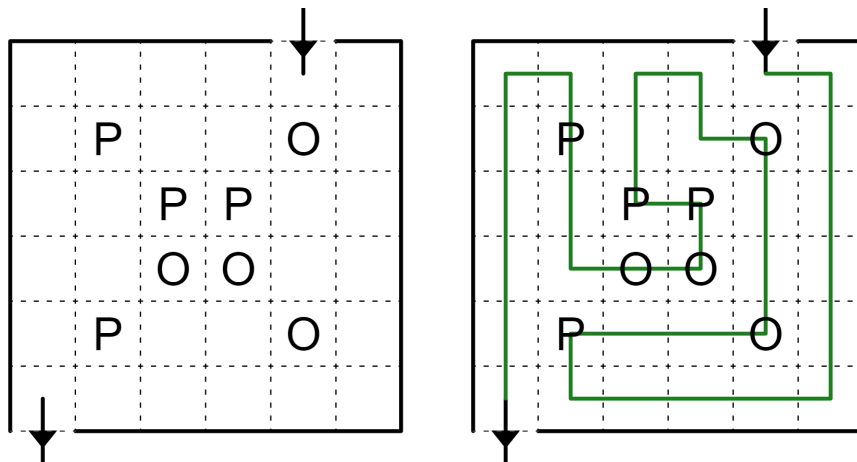

[Solve on Penpa+](#)

#7 **All or Nothing** (rows 76 – 91) by Eric Fox

The path visits each boldly outlined region at most once and if it does, it visits every cell in the region. Two regions sharing an edge cannot both be unvisited. (Only groups of cells which are fully enclosed by bold borders within this subgrid are considered regions.)

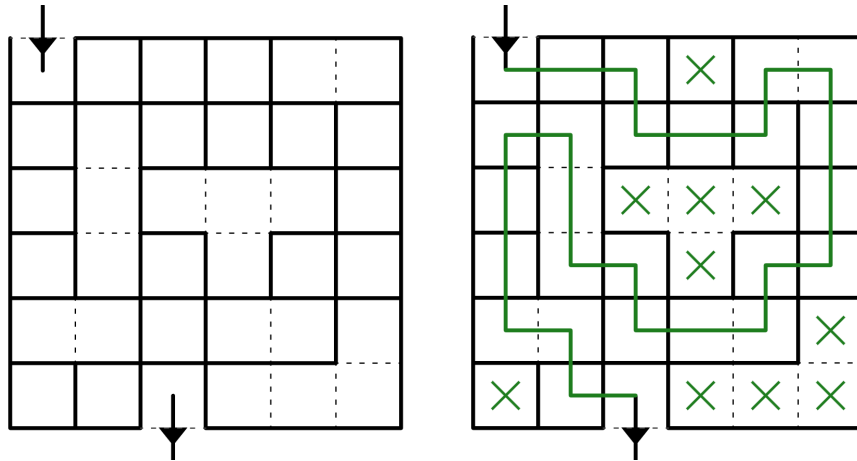

[Solve on Penpa+](#)

#8 **Myopia** (rows 89 – 104) by Ammar Fathin Sabili

Arrow clues indicate all of the orthogonal directions in which a path segment appears closest to the clued vertex.

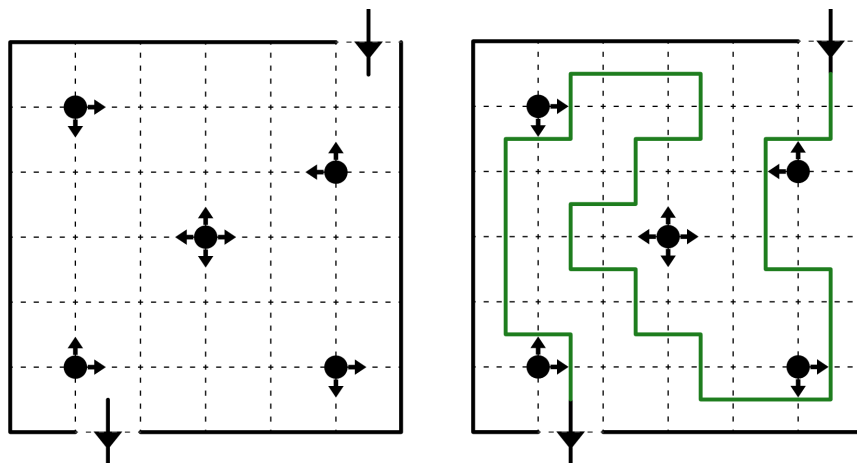

[Solve on Penpa+](#)

#9 **Yajilin** (rows 102 – 117) by DireKrow

Shade some cells so that no two shaded cells are orthogonally adjacent. Grey cells can be neither shaded nor visited. The path visits every remaining unshaded cell. Clues represent the number of shaded cells in a straight line in the indicated direction (clues can see through grey cells).

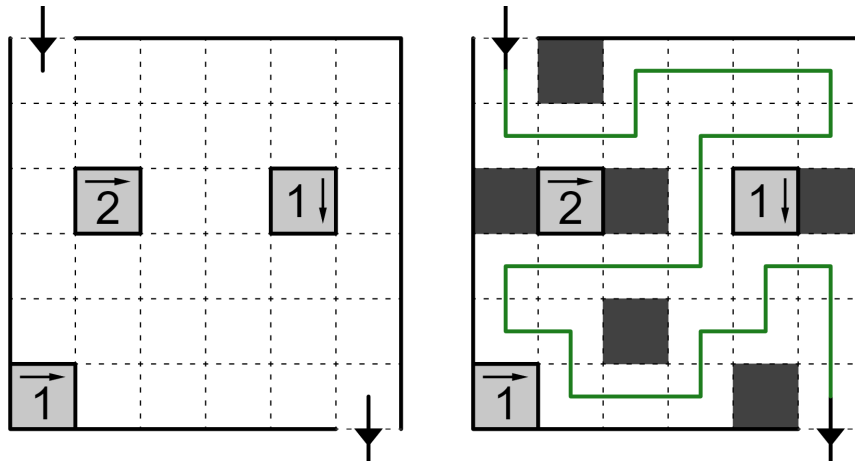

[Solve on Penpa+](#)

#10 **Canoe Slalom** (rows 115 – 130) by yosh

The path cannot travel along bold dotted lines. The path must cross each bold dotted line exactly once.

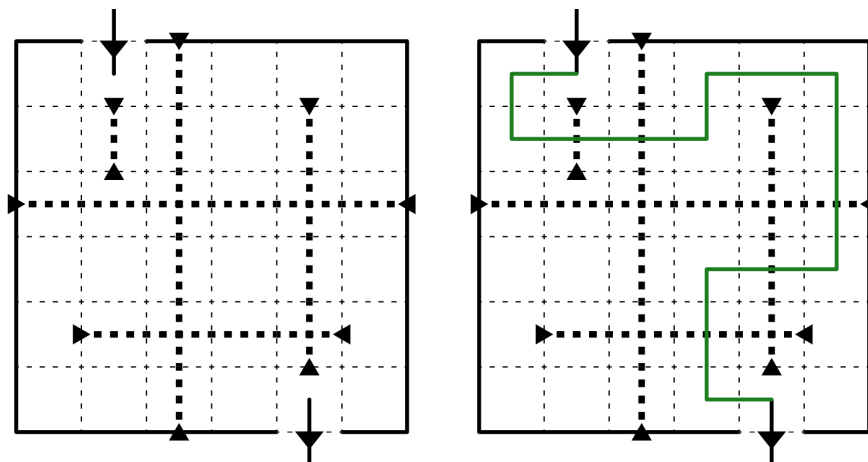

[Solve on Penpa+](#)

#13 **Rail Pool (Partial)** (rows 154 – 169) by Blaž Urban Gracar

Some boldly outlined regions contain number clues. If a straight path segment visits any cells of a clued region, its length must match one of these numbers. Each number must correspond to at least one such path segment. Question marks represent any positive integer, but numbers cannot repeat within a region. (Only groups of cells which are fully enclosed by bold borders within this subgrid are considered regions.)

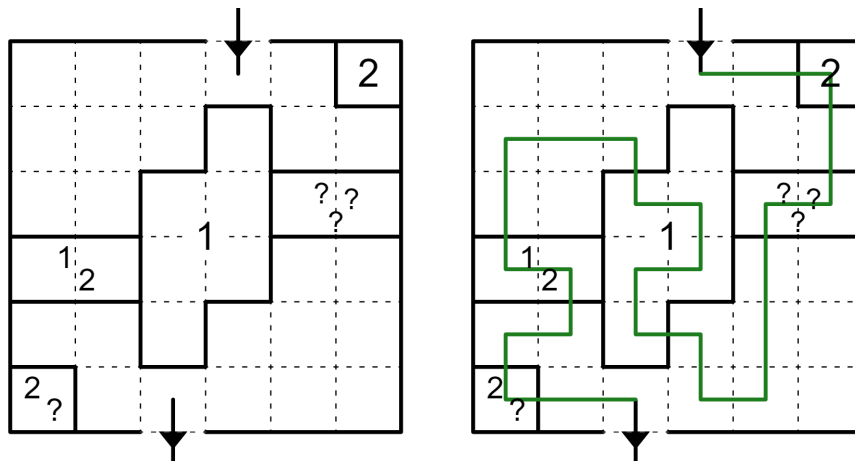

[Solve on Penpa+](#)

#14 **Ice Walk** (rows 167 – 182) by Walker

The path visits every number clue. The path may not turn on icy cells, but can cross itself on icy cells. A number indicates how many cells make up the continuous non-icy section of the path that the number is on.

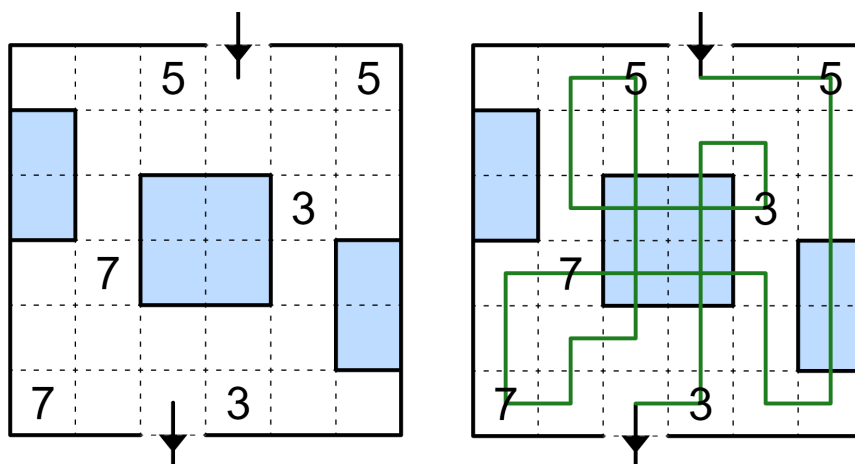

[Solve on Penpa+](#)

#15 **Castle Wall** (rows 180 – 195) by dohz

The path cannot visit outlined white, grey or black clue cells. White clue cells must be fully enclosed by the path, while black clue cells must not be enclosed. A number represents the sum of the lengths of path segments in the indicated direction **within this subgrid**.

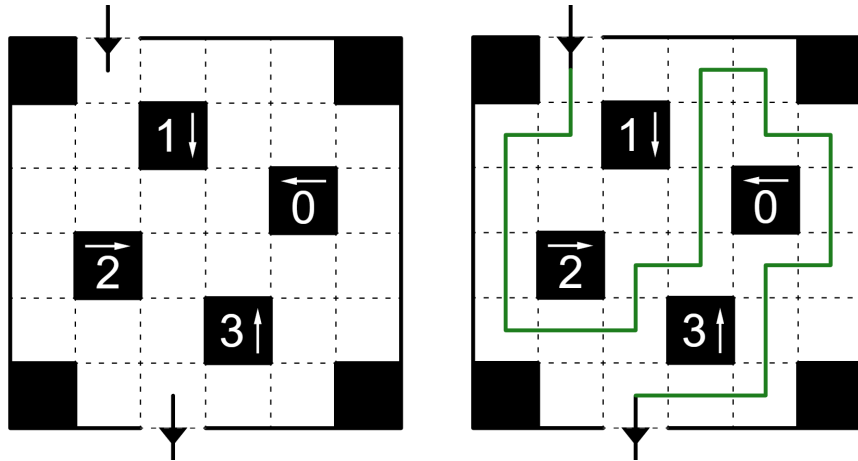

[Solve on Penpa+](#)

#16 **Turning Fences** (rows 193 – 208) by Sam Cappleman-Lynes

Circled number clues indicate how many of the four surrounding cells contain turns of the path.

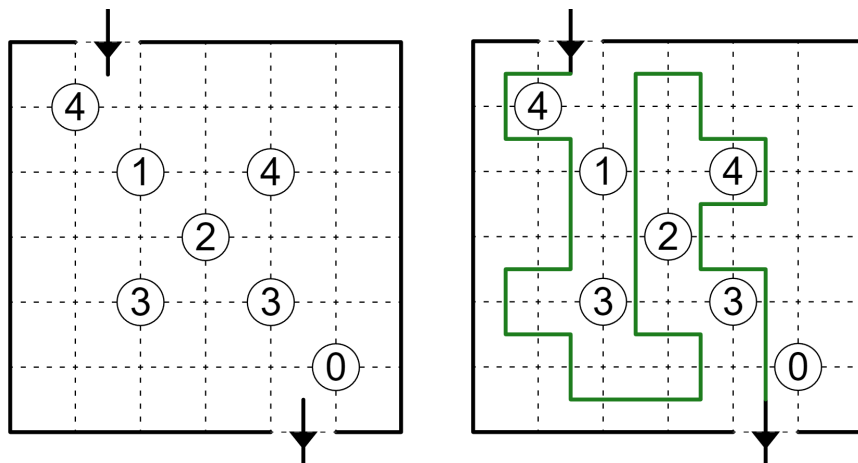

[Solve on Penpa+](#)

#17 **Persistence of Memory (Full)** (rows 206 – 221) by phenomist

The path visits every cell. If two shaded regions are the same shape and orientation, the line segments within them must be identical.

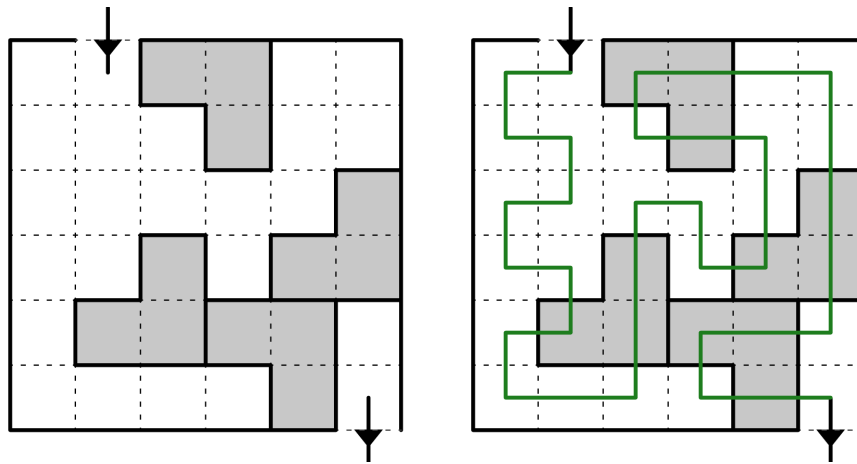

[Solve on Penpa+](#)

#18 **Maxi Path** (rows 219 – 234) by au voleur!

The path visits every cell. A number in a region represents the number of cells occupied by the longest continuous path section within the region.

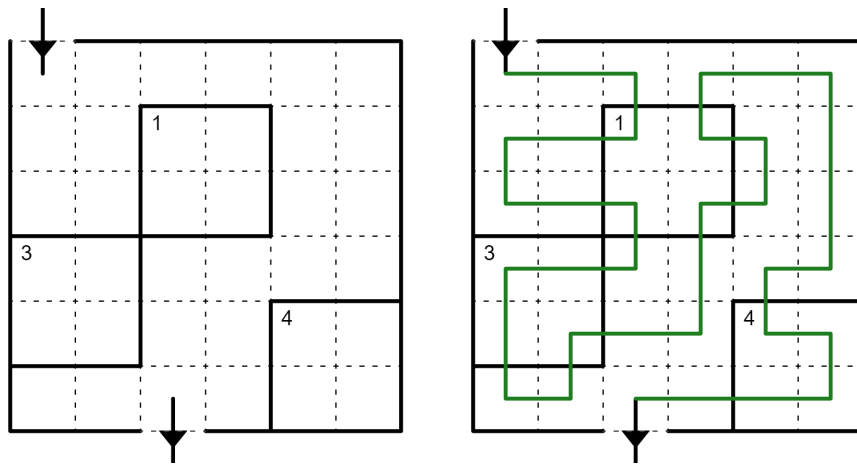

[Solve on Penpa+](#)

#19 **Moon or Sun** (rows 232 – 247) by Zachary Barbanell

The path visits each region exactly once. Within a region, the path must visit all moons and no suns, or all suns and no moons. A region containing only suns or only moons must have its clues visited. The path may not visit the same type of clue in two consecutively visited regions of this subgrid (even if it leaves the subgrid in between).

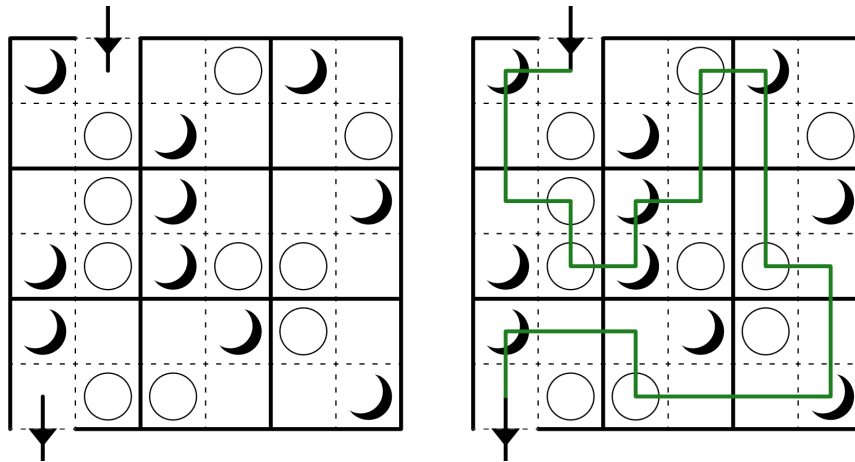

[Solve on Penpa+](#)

#20 **Crossing Statue Park Path** (rows 245 – 260) by Teal

Place each shape from the given banks into the corresponding rows so that no two shapes share an edge, even if they are from different shape banks. Rotating and reflecting the shapes is allowed. Cells with black circles must be used by a shape, and cells with white circles must not be used by a shape. The path visits every cell not used by a shape and may cross itself while going straight.

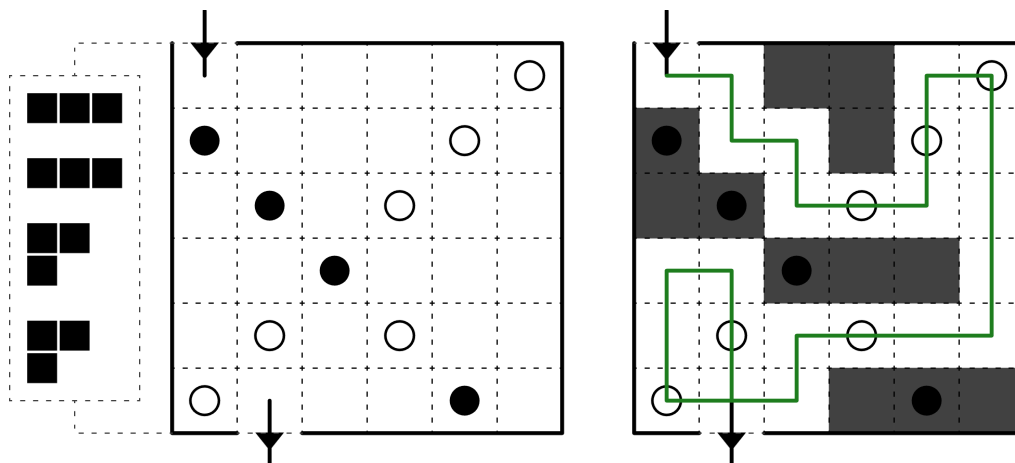

[Solve on Penpa+](#)

Shape banks for the main puzzle:

- The main section of this subgrid (rows 248 – 257) contains two copies each of the I, L, S and T **tetrominoes**.
- The overlap sections (rows 245 – 247 and 258 – 260) share a single shape bank containing two copies each of the I and L **tetrominoes**.

#21 **Country Road** (rows 258 – 273) by Jonah Ostroff

The path visits each region exactly once. A number in a region represents how many cells in the region are visited by the path. Orthogonally adjacent cells across a region border may not both be unused by the path.

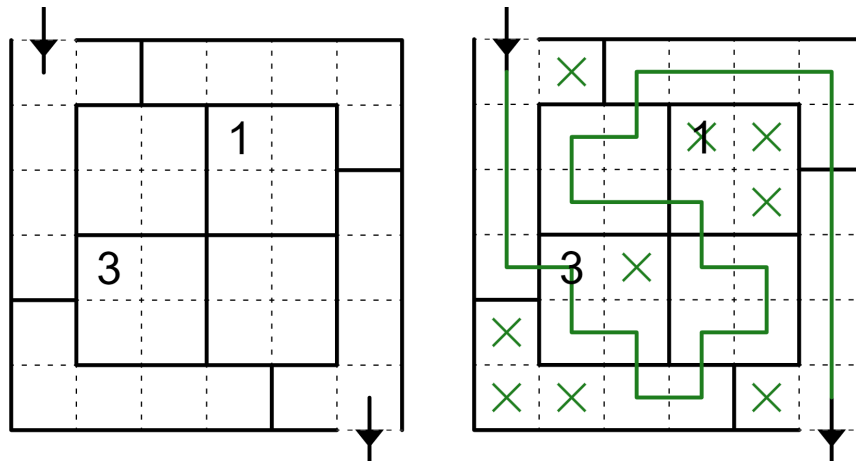

[Solve on Penpa+](#)

Note: the question mark in the overlap section takes the same value for both Country Road and Hinge Path.

#22 **Hinge Path** (rows 271 – 286) by scor

Shade some cells such that each group of orthogonally connected shaded cells is cut only once by a single straight segment of region borders, across which it must have reflectional symmetry. Numbered regions must contain the indicated amount of shaded cells. The path visits every unshaded cell.

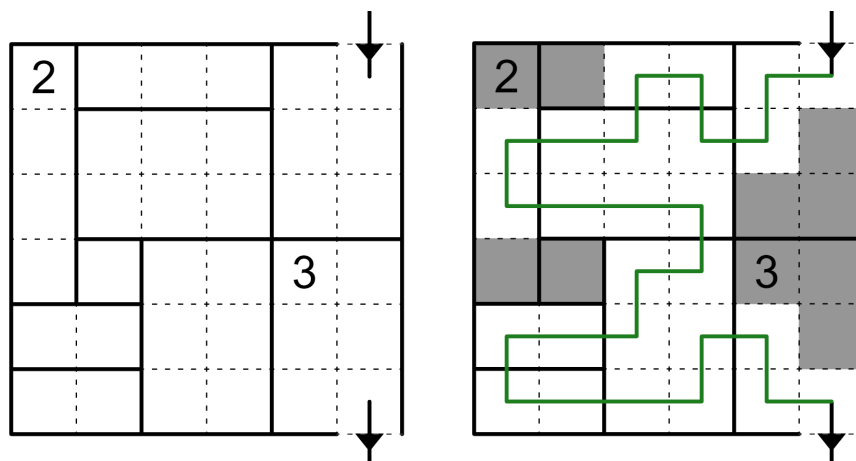

[Solve on Penpa+](#)

#23 **Simple Knight's Tour** (rows 284 – 299) by Deusovi

The path visits every unshaded cell exactly once. At each ♞, the path switches between orthogonal movement and taking knight's moves (two cells in one direction and one cell in a perpendicular direction). Knight's moves may cross over other parts of the path. Knight's moves cannot leave this subgrid.

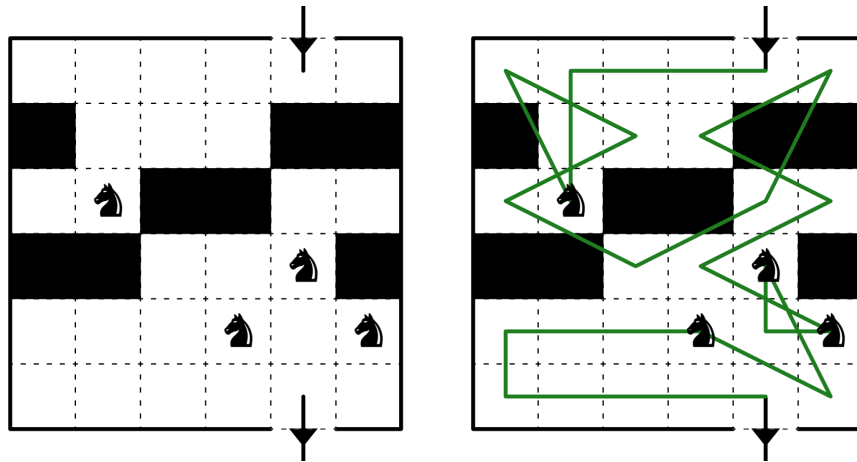

[Solve on Penpa+](#)

#24 **Equality** (rows 297 – 312) by bakpao

Shade some cells. The path visits every unshaded cell. Number clues indicate the number of shaded cells in the region. The path visits each region at least twice. Each visit to a region must visit the same number of cells.

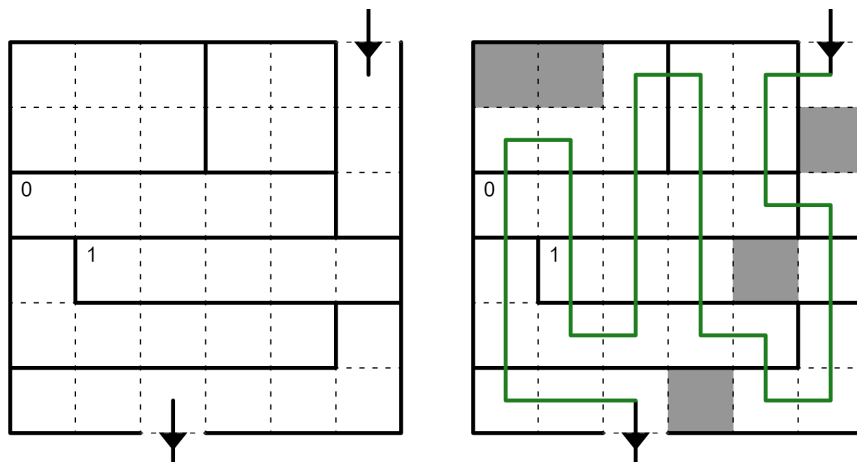

[Solve on Penpa+](#)

#25 **Oriental House** (rows 310 – 325) by wen

The path passes through every unshaded cell. The path visits every arrow. When the path passes through an arrow, either the entrance or the exit of the current visit to this region must match the direction of the arrow.

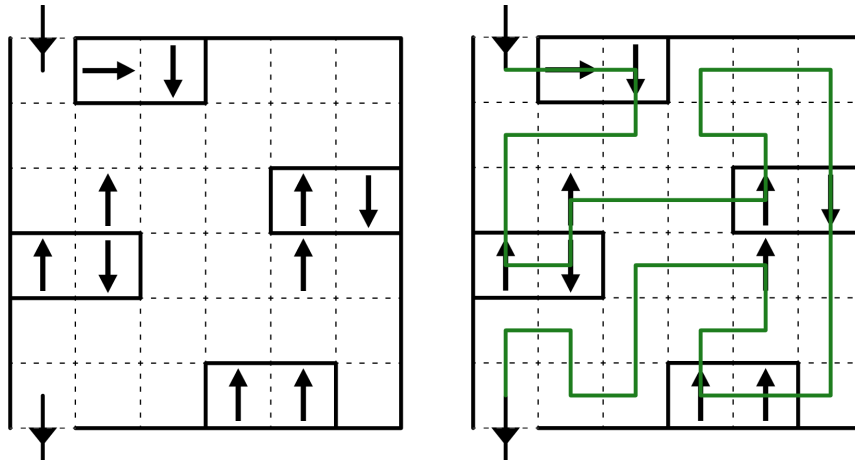

[Solve on Penpa+](#)

#26 **Alternating Kouchoku** (rows 323 – 338) by kays

Circled letter clues and black dots are nodes. The path visits each node exactly once. The path visits all nodes containing the same letter consecutively, without any other types of nodes in between. The path visits at least one black dot between nodes containing different letters. The path may intersect itself at right angles. At each black dot, the path switches between orthogonal movement and Kouchoku movement (stepping directly in a straight line from one node to the next, at arbitrary angles). Kouchoku steps may not intersect a different node.

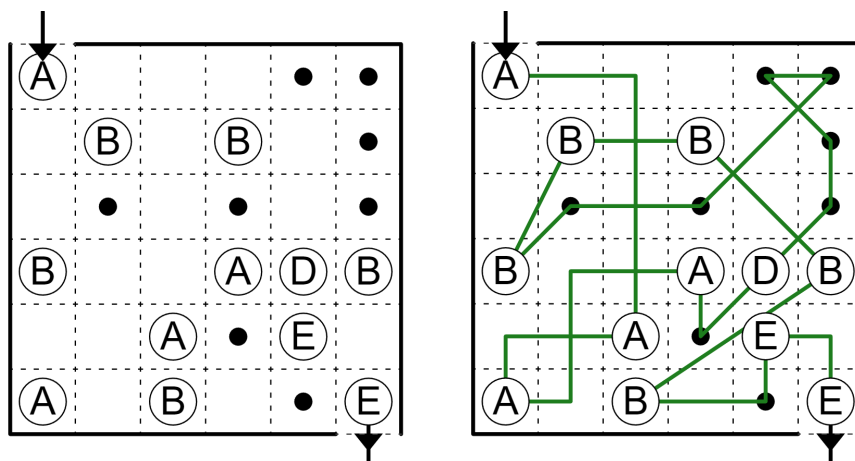

[Solve on Penpa+](#)

#27 **Train Stations** (rows 336 – 351) by Christian König (CJK)

The path passes through every cell. The path may intersect itself, but all crossings are given. The path moves straight through number clues, which must be visited in order. Each question mark is a different number from 1 to N (without duplicating a given number), where N is the total number of clues.

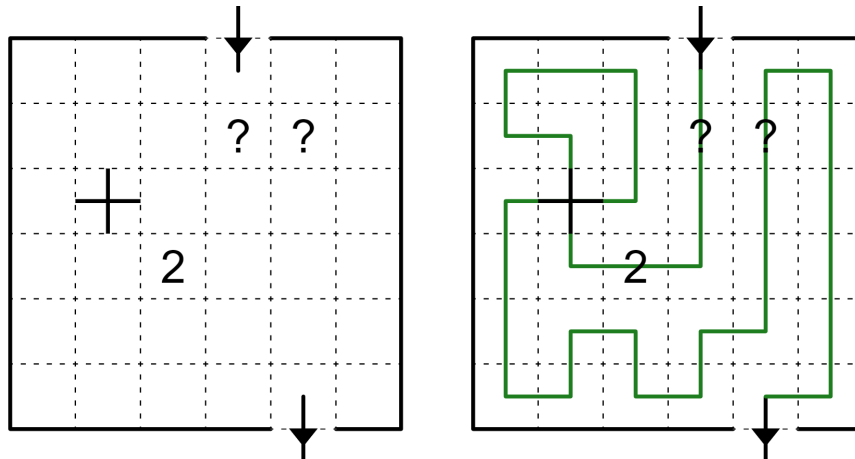

[Solve on Penpa+](#)

#28 **Balance Path** (rows 349 – 364) by lemononmars

The path visits every circle. Whenever the path visits a white (black) circle, the lengths of the straight line segments going in and out of the circle on this visit must have equal (unequal) length. If the circle is numbered, the number indicates the sum of these two segment lengths.

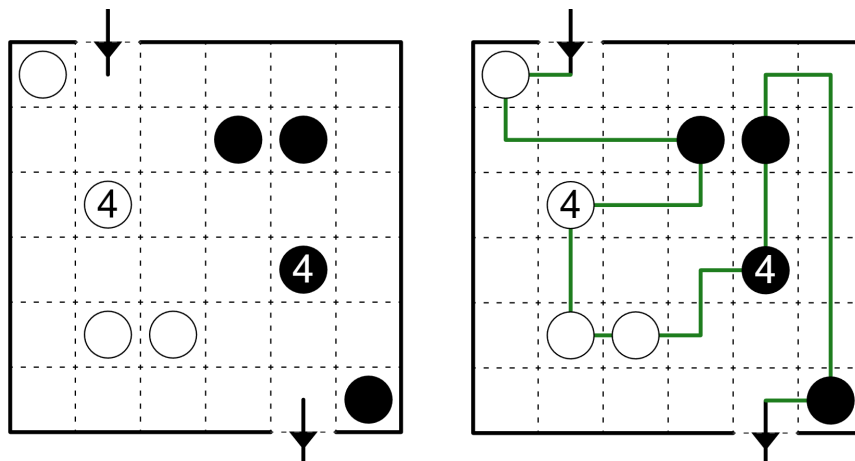

[Solve on Penpa+](#)

#29 **Regional Yajilin** (rows 362 – 377) by Tonta

Shade some cells so that no two shaded cells are orthogonally adjacent. Numbered regions must contain the indicated amount of shaded cells. The path visits every unshaded cell.

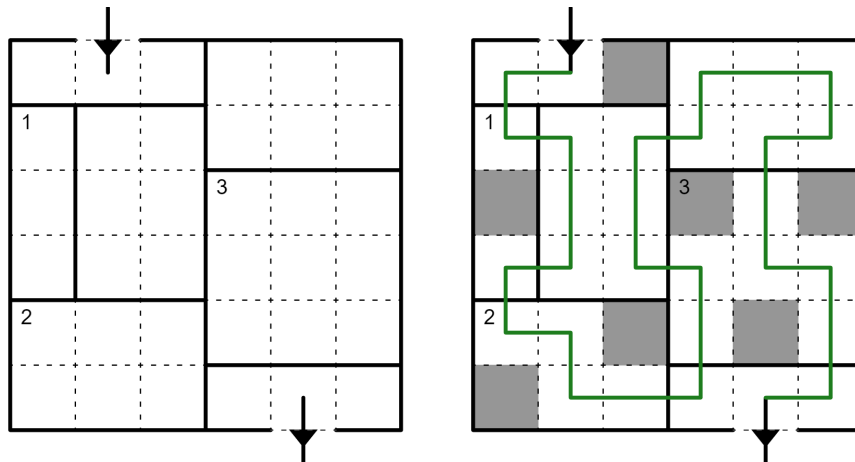

[Solve on Penpa+](#)

#30 **Slalom** (rows 375 – 390) by moeve

The path cannot travel along dotted lines. The path must cross each dotted line exactly once. If a number N is pointing at a gate, it must be the Nth gate visited from the start of the path.

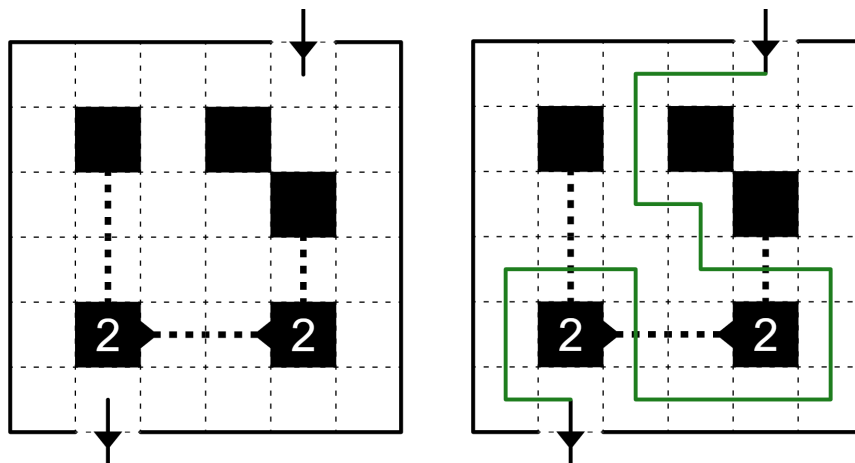

[Solve on Penpa+](#)

#33 **Mukkonn Enn** (rows 414 – 429) by Rubrica

The path visits every unshaded cell. When the path enters or exits a clued cell on a side with a number, it must travel in a straight line for exactly the indicated number of cells (turning on the Nth cell, where N is the value of the clue). A number does not necessarily mean that the clue must be exited from its side.

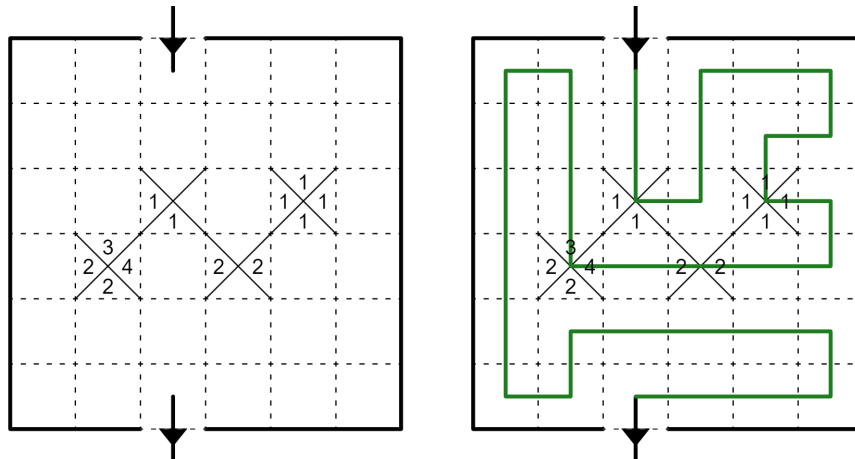

[Solve on Penpa+](#)

#34 **Cross Border Parity Path** (rows 427 – 442) by Craig Kasper

The (entire) path is divided into light and dark sections. Every time it crosses a given bold (or bold dotted) border in this subgrid, the path alternates between light and dark. The colouring of the start of the path is unknown. White (black) number clues, if given, indicate how many cells in the region are visited by light (dark) sections of the path.

You may assume that the path cannot return to this subgrid after reaching a subgrid with non-standard topology (such as crossings) below.

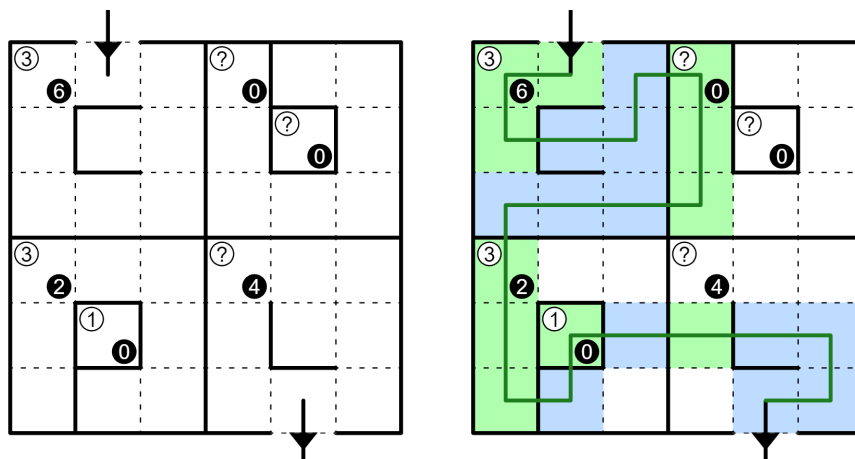

[Solve on Penpa+](#)

Note: Cross Border Parity Path is not affected by borders drawn as part of the Fillomino solution.

#35 **Thoroughfare Fillomino** (rows 440 – 455) by Joseph Howard

Divide this subgrid into regions along gridlines (independently of any regions given by the previous subgrid). Two regions of the same size may not share an edge. Number clues indicate the size of the containing region. The path visits each region at most once and if it does, it visits every cell in the region.

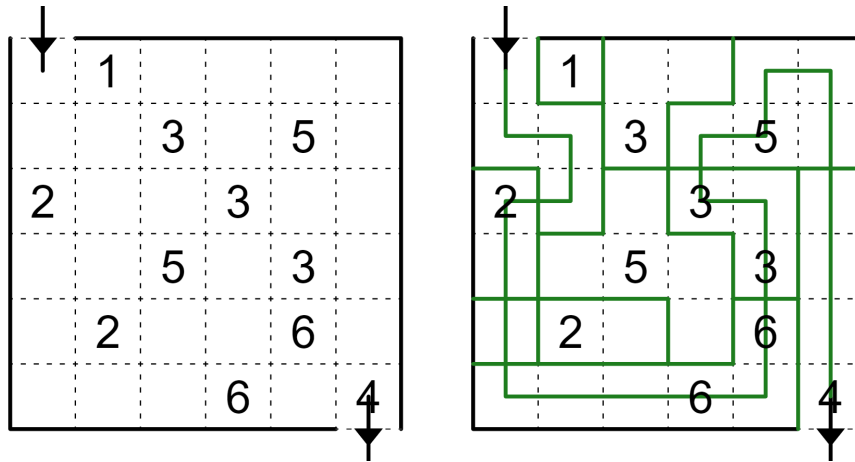

[Solve on Penpa+](#)

#36 **Pentopia Path** (rows 453 – 468) by Wessel Strijkstra

Shade some cells such that the shaded cells form pentominoes (groups of five orthogonally connected cells) which do not touch each other, not even diagonally. No two pentominoes have the same shape, counting rotations and reflections as the same.

Myopia clues cannot be shaded, and contain arrows indicating all of the orthogonal directions which tie for having a shaded cell appearing closest to the clued cell. At least one shaded cell must appear in the direction of an arrow.

The path visits every unshaded cell (including clue cells).

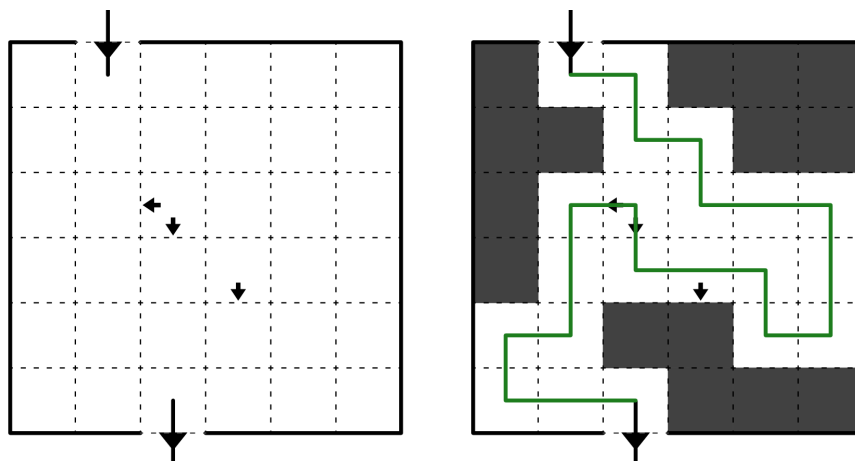

[Solve on Penpa+](#)

#37 **Crossroads** (rows 466 – 481) by Emerson Golladay (Rook)

The path visits every unshaded cell. Number clues indicate how often the path crosses the network of bold lines attached to the clue.

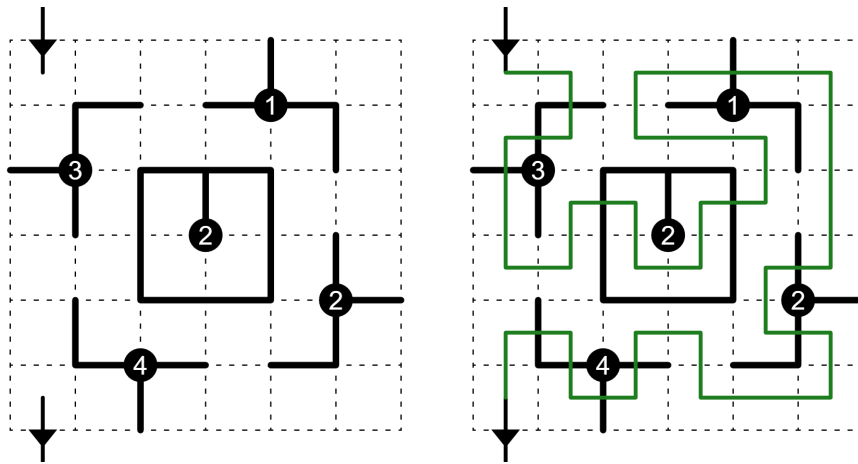

[Solve on Penpa+](#)

#38 **Exercise** (rows 479 – 494) by Barbitos

When the path moves into a block, that block gets pushed one cell in the path's direction. Each block can only be pushed once and cannot be pushed into another block. Shade the cells corresponding to the final positions of all blocks. The path visits every unshaded cell.

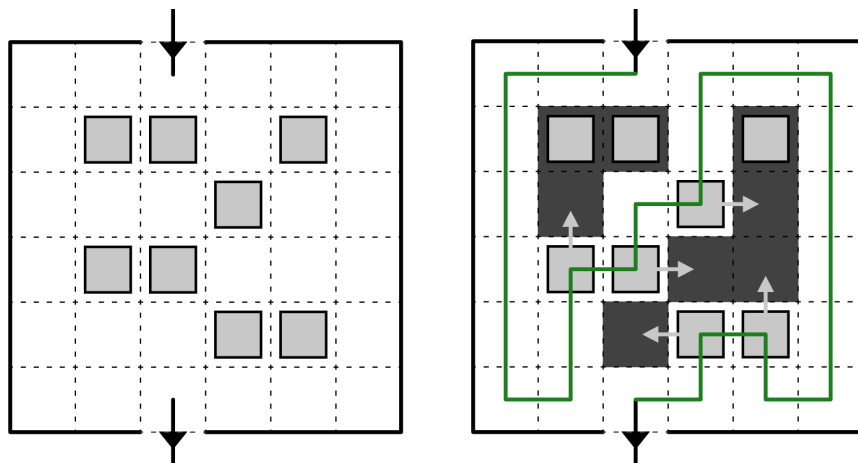

[Solve on Penpa+](#)

#39 **Portal Patrol** (rows 492 – 507) by Seren ☆

The path visits every white circle and no black circles. No 2x2 square of cells is entirely visited or unvisited by the path. White circles are portals. Upon entering a portal, the path is transported to the other portal with the same number and continues in the same direction. Each pair of portals is used exactly once. (Do not draw a line connecting the portals.) For the purposes of topological rules in other subgrids, consider the path in this subgrid as unbroken.

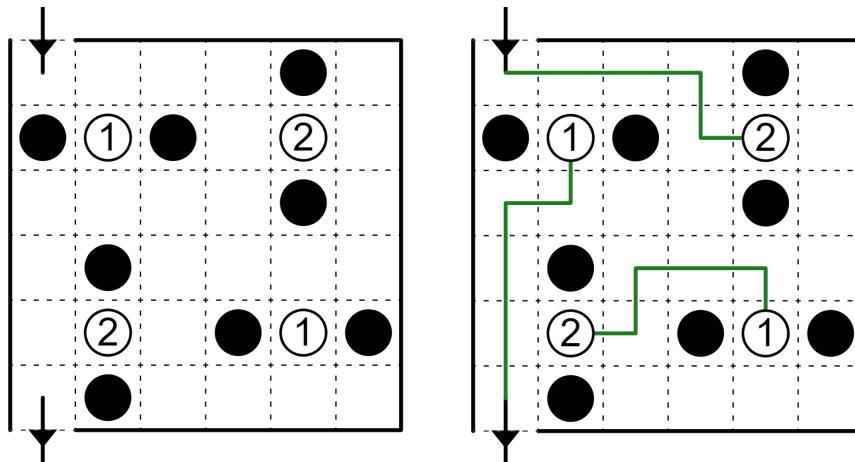

[Solve on Penpa+](#)

Note: there are no more crossings or other topological oddities after this point.

#40 **Midpath** (rows 505 – 520) by djmathman

The path passes straight through every circle. Each circle marks the centre of the straight line segment it lies on.

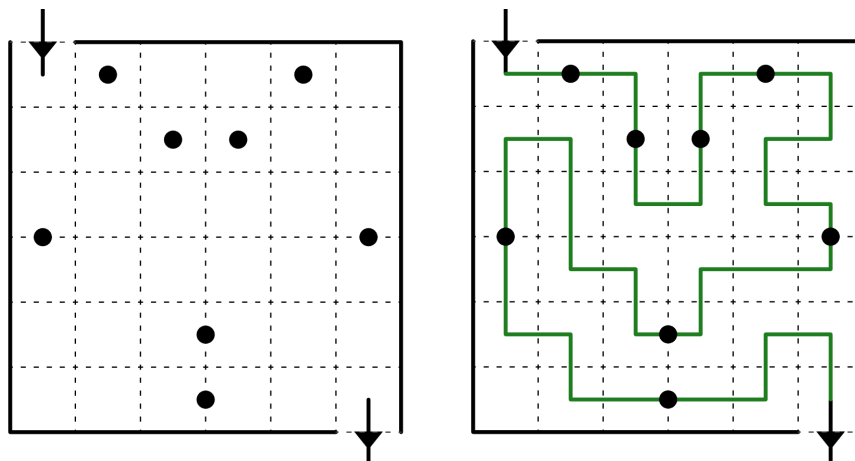

[Solve on Penpa+](#)

#41 **Running Path** (rows 518 – 533) by Elyot Grant

The path visits every flag. All path lengths between consecutive flags are equal.

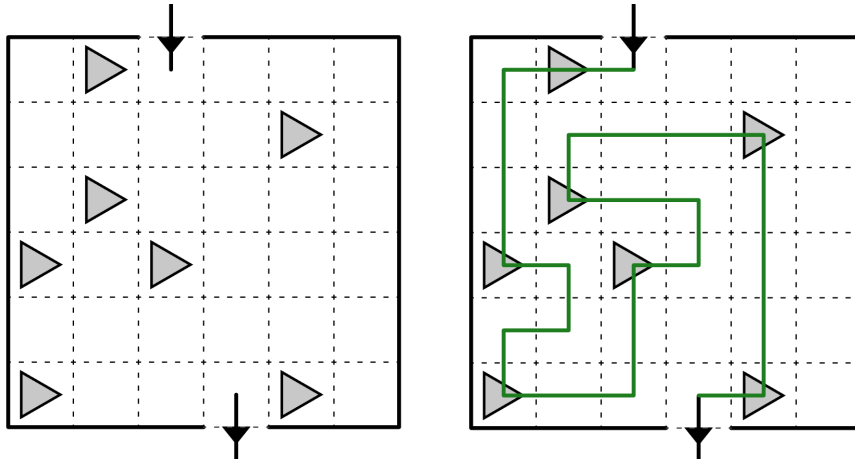

[Solve on Penpa+](#)

#42 **Inturnal** (rows 531 – 546) by muhorka

Plain number clues indicate how many of the cell's four vertices can reach the right edge of the grid without crossing the path.

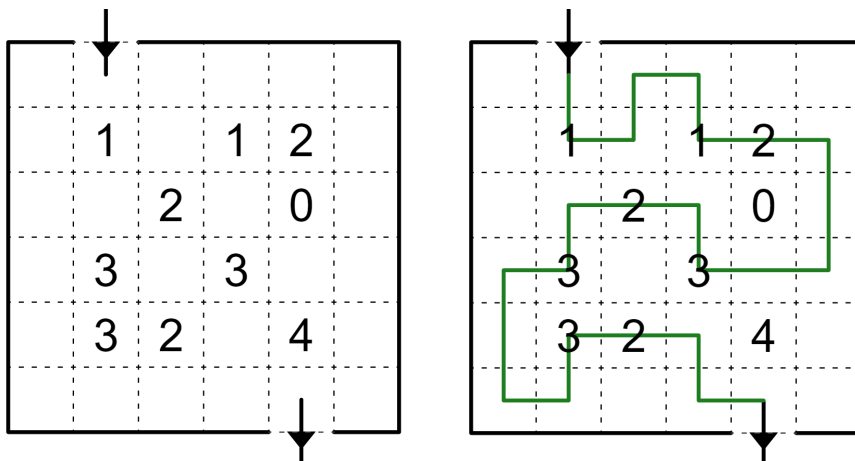

[Solve on Penpa+](#)

#43 **Nurikabe-Like Path** (rows 544 – 559) by IHNN

The path cannot visit circled number clues. Every orthogonally connected group of unvisited cells in this subgrid contains exactly one circled number clue, indicating the total number of cells in the group (even if some of those cells are outside this subgrid).

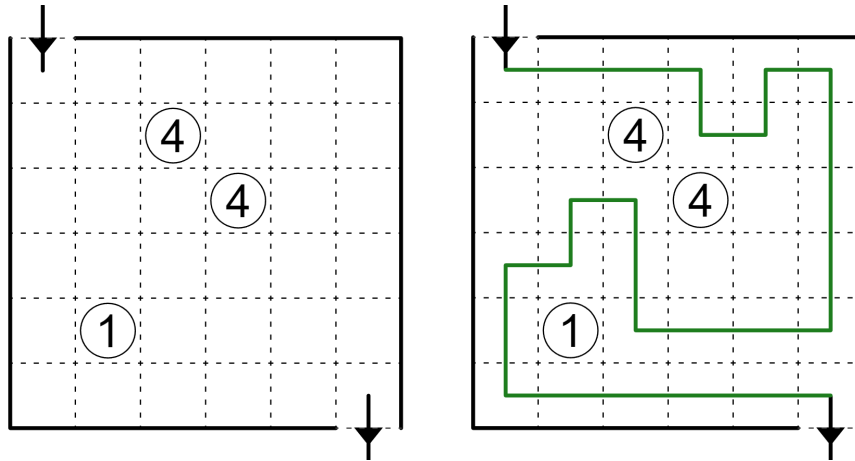

[Solve on Penpa+](#)

#44 **Linesweeper** (rows 557 – 572) by Stef

Plain number clues cannot be visited and represent how many of the (up to) eight cells surrounding the clue are visited by the path.

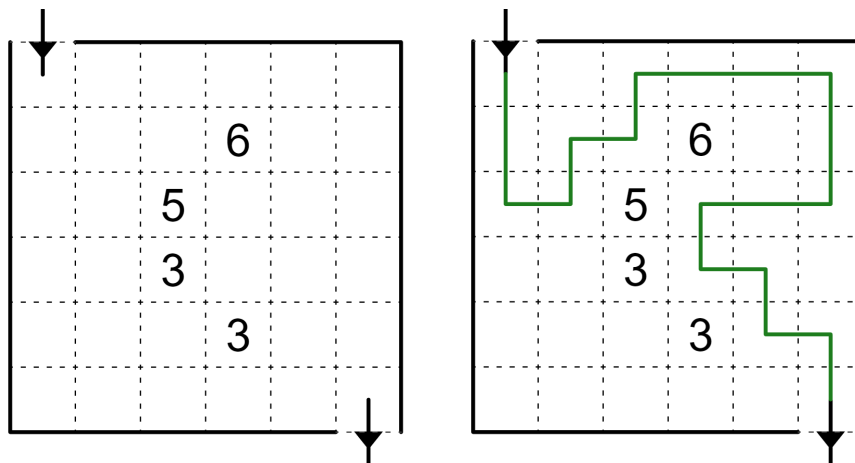

[Solve on Penpa+](#)

#45 **Bhai Bahan** (rows 570 – 585) by Prasanna Seshadri

The path visits every circle. Consider the path split into segments, such that within a segment, it either turns in each cell or goes straight in each cell, and segment types alternate along the path. When two circles are orthogonally adjacent, they belong to different types of segments (even if they are not directly connected by the path). Numbered circles indicate the length of the current segment.

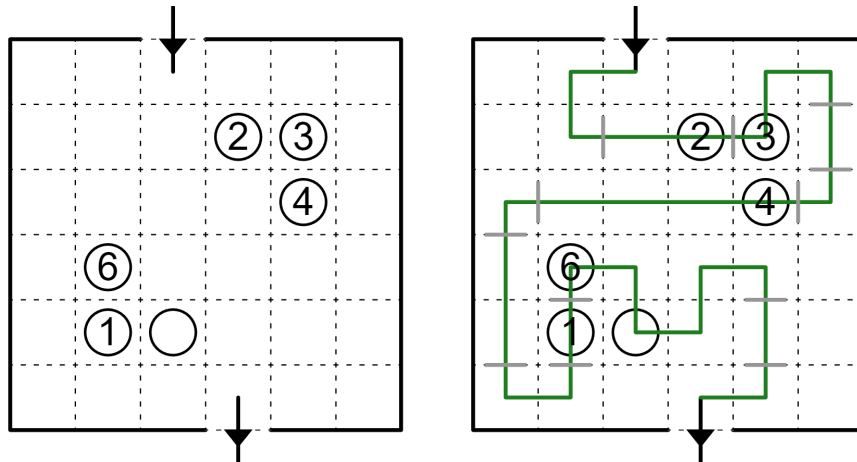

[Solve on Penpa+](#)

#46 **Alternate Path** (rows 583 – 598) by Jamie Hargrove

The path visits every square. Along each section of the path within this subgrid, black and white squares alternate (the pattern may reset when the path leaves and re-enters the subgrid).

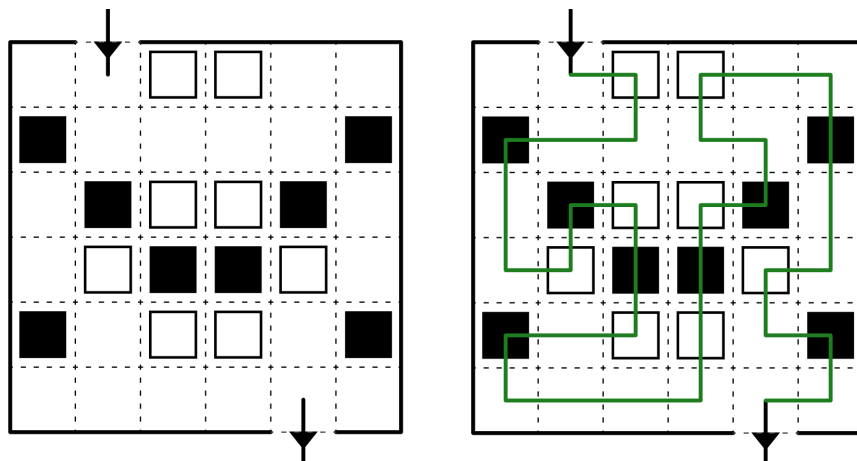

[Solve on Penpa+](#)

#47 **Transporteur (Full)** (rows 596 – 611) by jovi_al

The path visits every cell. White square clues are parcels for a given destination and with a given weight. Black squares are destinations. A delivery driver travels along the path. The driver picks up a parcel when visiting its cell and delivers all parcels of the matching letter when visiting a destination. The driver can never hold parcels with a total weight of more than 3 units, but it may hold parcels for different destinations simultaneously. All parcels must be delivered to their destinations.

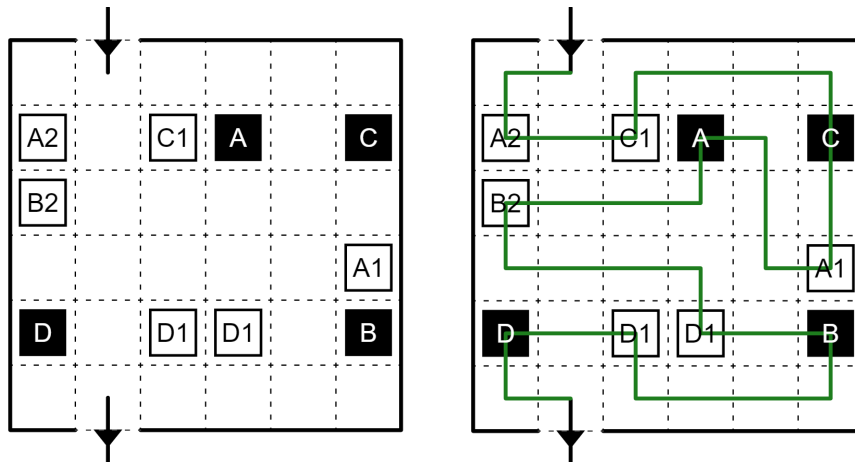

[Solve on Penpa+](#)

#48 **Hotaru Path** (rows 609 – 624) by wormsofcan

The path visits every white circle and exits the cell in the direction of the dot. Number clues indicate how often the path turns between this circle and the next along the path.

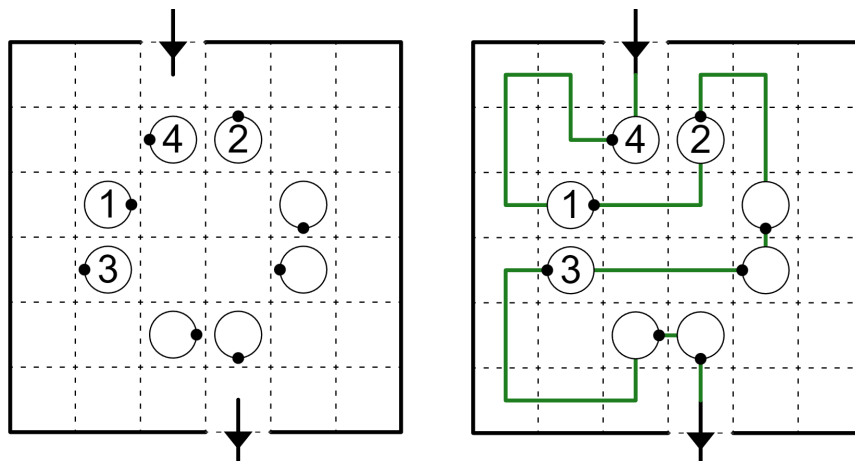

[Solve on Penpa+](#)

#49 **Slitherlink** (rows 622 – 637) by Rever

Number clues represent the number of line segments drawn surrounding the clue (up to four).

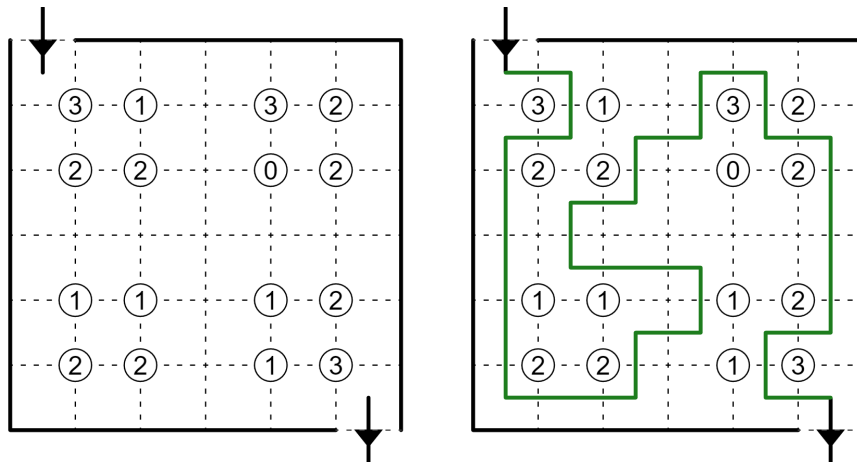

[Solve on Penpa+](#)

#50 **Delta Walk** (rows 635 – 647) by William Hu (TheGreatEscaper)

The path visits every orange cell. A single offshoot branches off the path in every orange cell and connects to the edge of the grid somewhere. Offshoots cannot leave this subgrid. The path or an offshoot visits every number clue. A number indicates how many cells make up the continuous white-cell section of the path or offshoot that the number is on.

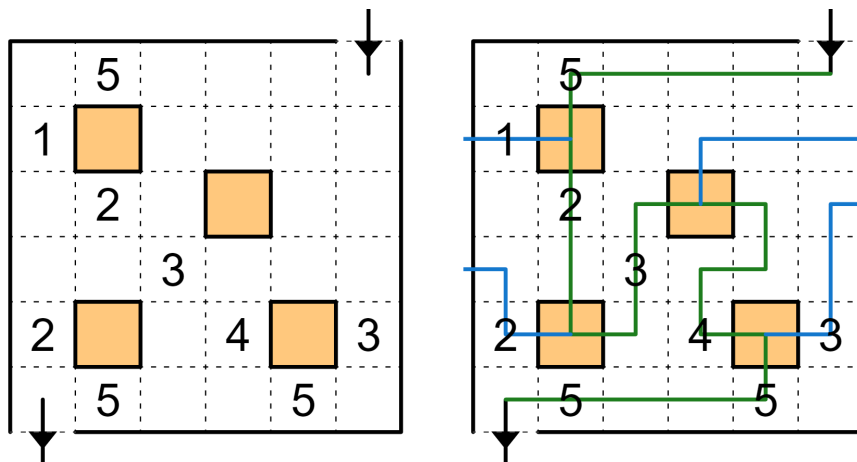

[Solve on Penpa+](#)